



News @ BRT

Beaumont Runner Technologies, Inc.

Volume III, Issue 1 • April 2003

LOOK FOR BRT AT NPE 2003

Inside this issue:

| | |
|--|---|
| Look For Beaumont Runner Technologies at NPE 2003 | 1 |
| Annual Site License Demand Grows Strong | 1 |
| Beaumont Runner Technologies and Sunset Mold Form Strategic Alliance | 2 |
| Hoffman Presenting Paper at MME | 2 |
| Case Study: No Leaks for Medical Molder | 3 |
| BRT and Custom Tool & Design To Benchmark All Multi-Cavity Molds | 4 |

“They don’t make ’em like they used to,” but Beaumont Runner Technologies, Inc., wants to challenge that notion at NPE 2003. Moreover, can a processor make “a silk purse from a sow’s ear?” That’s exactly what BRT plans to show and “prove” at their 400 sq. ft. exhibit at **Booth #11224, East Hall, Level 3, June 23-27.**

In a radical departure from most firms exhibiting at NPE, Beaumont plans to mold parts on a 1944 Model 1 Van Dorn plunger injection molding machine supplied by Penn State Behrend in Erie, PA. The “retro” approach has a point: the firm’s patented technology, available to licensees, can and will make any combination of IM machines and hot or cold runner molds – old or brand new – manufacture higher quality parts.

Specifically, the technology is not a new machine, or auxiliary system or

add-on: Beaumont’s product is a patented ‘melt-management’ technology that allows processors to optimize the final quality of molded parts on a mold-by-mold basis by giving them the ability to control the material after it leaves the injection nozzle. It is marketed under the MeltFlipper™ name. Benefits include, in addition to improved part quality, reduced cycle times, faster mold balancing and production startup, speedier product time to market, and reduced scrap.



Visit BRT’s booth for a chance to win one of several valuable prizes, including the book “Successful Injection Molding - Processing, Design, & Simulation,” a copy of “The 5 Step Process” software, or a FREE license of MeltFlipper™ technology! Check out <http://meltflipper.com/npe3.html> for more details.

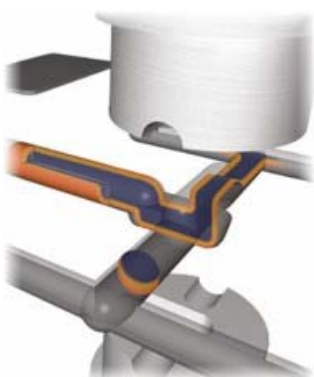

ANNUAL SITE LICENSE DEMAND GROWS STRONG

Interest in BRT’s new *unlimited-use* annual site license remains strong, even in a weak economy.

“Having complete access to MeltFlipper technology saves time. It gets melt rotation technology into the mold before commissioning, rather than after bugs are found, which gives you saleable parts faster,” says John Beaumont, BRT president. “Companies that compete vigorously on the world market need to keep every competitive edge they have. These are

(Continued on page 2)



BEAUMONT RUNNER TECHNOLOGIES AND SUNSET MOLD FORM STRATEGIC ALLIANCE

Molding Enhancement System Gives Mold Maker Competitive Edge

Beaumont Runner Technologies, Inc., announces the establishment of a strategic alliance with one of the South's leading mold making firms – Sunset Mold Corporation of Venice, FL. Specifically, Sunset has purchased a multi-year license from Beaumont in moves to more successfully compete with foreign mold makers.

Under terms of the strategic alliance, Sunset will utilize the patented MeltFlipper technology on molds being developed for customers. This has resulted with molds producing higher quality parts and enabling processors using Sunset molds to get into production more quickly. Mold maker officials additionally note that application of this technology – for improving melt flow and enhancing product quality with melt rotation technology – reduces both cycle time and increases the structural integrity of molded parts.

In making this announcement, both firms claim that the rationale for the alliance includes the ability of the technology to provide a balanced fill the first time

molds are shipped to customers. Notes Sunset President Steven Sellin, “we no longer have to tweak gates or modify runners, what with the Beaumont MeltFlipper technology making it possible to turn mold making into a science and enabling us to get rid of the ‘black magic’ we needed to help customers produce deliverable parts. In fact, the technology more than pays for itself often times before the mold goes into production.”

**“the
technology
more than
pays for itself
often times
before the
mold goes into
production”**

Additionally, Sunset customers claim that retrofits of MeltFlipper technology where making an auto connector with a grooved O-ring has been extremely well received. “The O-ring groove must be perfectly round,” says the Sunset Mold president, “and in the past we unsuccessfully tried to compensate by oversizing the steel dimensions, necessitating us to tweak the molds as they shoot. We’d also make the O-ring portion of the mold into an oval shape so that when the plastic shrinks, it became round. With this new technology, the groove comes out perfectly round the very first time.”

For more information on this application and/or licensing of the MeltFlipper technologies, contact a Beaumont Runner Technologies, Inc., representative at 814-899-6390 or meltflipper@runnertech.net.

DEMAND GROWS STRONG (cont'd)

(Continued from page 1)

the companies we hear from most often regarding annual licensing, and who are most interested in applying the MeltFlipper proactively to each mold that they make.”

Site licenses are tailored to each client for their specific applications. In all cases, the customers are given unlimited licenses, bundled design services, and free consultation for potential MeltFlipper applications. For specific pricing details for your company, please contact BRT at 814-899-6390, or by email at meltflipper@runnertech.net.

Hoffman Presenting Paper at MoldMaking Expo 2003

Visiting MME in Cleveland? Make it a point to drop by Dave Hoffman's paper presentation. BRT's technical sales manager will discuss “Runner Designs: Shortening Mold Commissioning Times Through Melt Management Technology” at 1:30 p.m. Thursday, May 1.



CASE STUDY

No Leaks for Medical Molder

Company: King Systems Corporation
Noblesville, Indiana

Medical molder King Systems Corp. built a 16-cavity mold to produce a 90-degree elbow the company uses in its anesthesia-circuit product line. It was designed as a three-plate mold to allow each part to be gated on the top and to reduce the number of cams in the mold. The part was molded using a very low-melt acrylic.

Like most of King's parts, the elbow has crucial ISO diameter fits on the ends. The mating parts must seal to prevent anesthesia leak.

After sampling the mold King noticed that the fits in the eight outer cavities were a different size than the fits in the eight inner cavities. King spent many days trying different processing parameters to get all the parts in spec; when this didn't work, they altered the pins. This also was unsuccessful, because the parts did not reflect the proportionate change.

"We went around this circle a couple of times, with no acceptable results," says Tony Burden, operations manager of King's Plastics Technology Division. "We had read about the MeltFlipper technology in a trade magazine and although we were very skeptical, we felt that we had no other choice but to ask for their help. We sent them our mold design and about a week later they sent us back a recommended solution."

When King incorporated Beaumont Runner Technologies' MeltFlipper technology, the parts reflected the pins in the mold.

"This was good and bad," Burden said. "We now had a solution to the problem, but we had to make all new pins for the mold. We know now that this can be avoided by designing the MeltFlipper into a mold upfront so we don't have to worry about costly imbalances during sampling or production."

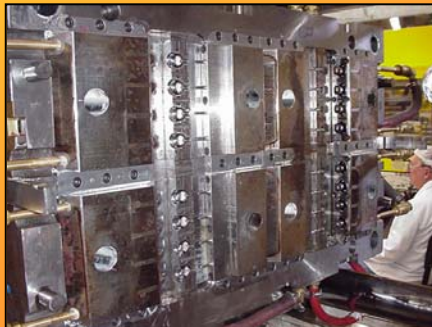

Left: A-Half of 16-cavity production tool.

Right: B-Half of 16-cavity production tool.

Left: Full-size view of the MeltFlipper runner system for the 16-cavity medical mold.

Right: Blow-up view showing the cavity orientation and MeltFlipper runner layout.

BRT AND CUSTOM TOOL & DESIGN TO BENCHMARK ALL MULTI-CAVITY MOLDS

Custom Tool & Design of Erie, Pa., recently announced that each multi-cavity mold it designs now will be benchmarked and evaluated by Beaumont Runner Technologies, Inc.

BRT offers a 5-Step Process evaluation strategy that makes it possible for the company to identify, quantify, and separate steel variation from shear-induced filling variation.

“We want to provide our customers with the best possible mold performance when they sample the mold for the first

time...and this relationship with Beaumont Runner Technologies, Inc. helps achieve this,” says Jeff Mertz, vice president of Custom Tool & Design. “Beaumont is the most innovative and knowledgeable company around when it comes to melt property management and troubleshooting mold filling imbalances. They’ll provide to us detailed reports that outline the source and magnitude of filling variation for each of our molds.”

“If the source is steel-related we can immediately identify the affected cavity, determine an

action plan, and resolve the issue. If MeltFlipper technology has not been implemented for some reason, and the variation is shear-related our customers will be notified and recommendations will be provided. Since the extent of the variation is quantified by Beaumont, the next time the mold is sampled we can determine the effectiveness of our solution.”

To learn more about this exciting new option for optimizing your molds, contact a Beaumont Runner Technologies, Inc. representative.



5091 Station Road
Erie, PA 16563-1702

Phone: 814-899-6390
Fax: 814-899-7117

Email: meltflipper@runnertech.net

Revolutionizing Runner Designs for Injection Molding



WE'RE ON THE WEB:
WWW.MELTFLIPPER.COM

Beaumont Runner Technologies, Inc. is the exclusive licensor of the MeltFlipper™ technology developed by John Beaumont, an associate professor of plastics engineering technology at Penn State Erie. The company is dedicated to revolutionizing melt delivery systems and design practices for both hot and cold runners in the plastics industry. With further R&D and an in-depth understanding of plastic flow characteristics, BRT continues to grow and has now expanded its capabilities and services beyond the development of MeltFlipper technologies. The BRT staff offers full engineering support to MeltFlipper licensees in the various plastics industries.

*The MeltFlipper technologies are patented approaches to melt-management and melt-rotation within a melt delivery system. The technologies reposition the shear-induced variations in hot or cold runner systems to create uniform filling and material properties in all cavities of a multi-cavity tool. By repositioning the melt to provide for natural symmetry, the MeltFlipper technology eliminates variations in temperature, viscosity, and other material properties to and within the inner and outer mold cavities. In addition to creating identical filling in high cavitation molds, the MeltFlipper technologies offer improved CpK, reduced part scrap and costs, and a wider processing window. The MeltFlipper technology is a low risk investment due to its 100% customer satisfaction **GUARANTEE** to solve the problems associated with filling imbalances.*